

THROUGH FRAME  
INSTALLATION

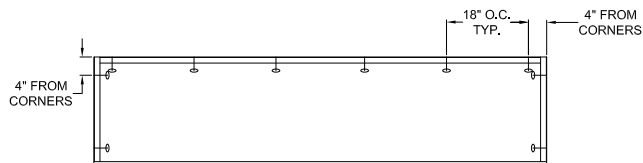

TYPICAL ELEVATION WITH FASTENER SPACING

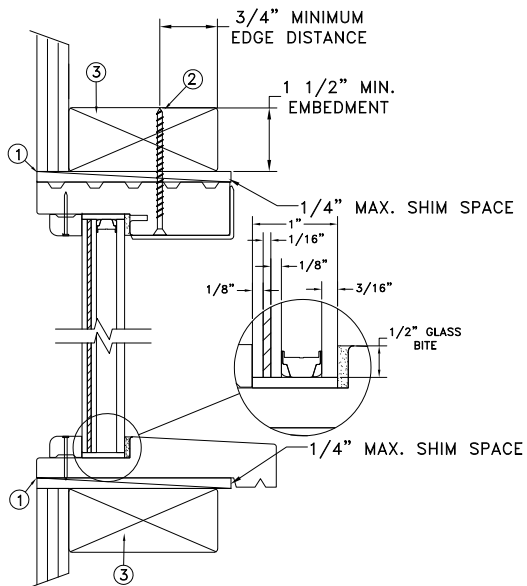

FRAME SECTION (TYP)  
VERTICAL SECTION

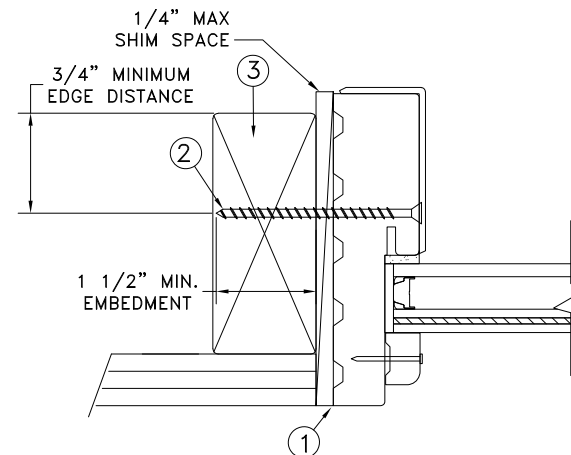

FRAME JAMB SECTION (TYP)  
HORIZONTAL SECTION

MAXIMUM FRAME	DP	IMPACT
99 1/2" x 24"	+65/-70	WZ3

MISSILE LEVEL D

**Installation Notes:**

1. Seal flange/frame to substrate. Sill shall be set on a continuous serpentine bead of structural grade silicone caulk when no fastener is used to anchor the sill (typical).
2. Use #8 X 2 1/2" PH or greater fastener through the head & side jambs with sufficient length to penetrate a minimum of 1 1/2" into the wood framing. For 2x wood frame substrate (min. S.G. = 0.42)
3. Host structure (wood buck, masonry, steel) to be designed and anchored to properly transfer all loads to the structure. The host structure is the responsibility of the architect or engineer of record for the project of installation.

**General Notes:**

1. The product shown herein is designed, tested and manufactured to comply with the wind load criteria of the adopted International Building Code (IBC), the International Residential Code (IRC), the Florida Building Code (FBC) and the industry requirement for the stated conditions.
2. All glazing shall conform to ASTM E1300.
3. At minimum, glazing is 3.0mm tempered - 12.0mm airspace - 3.0mm annealed - 2.3mm PVB interlayer by kurraray - 3.0mm annealed insulated glass.
4. Use structural or composite shims where required.

This schedule addresses only the fasteners required to anchor the unit to achieve the rated design pressure and impact performance (where applicable) up to the size limitations noted. It is not intended as a guide to the installation process and does not address the sealing consideration that may arise in different wall conditions. For the complete installation procedure, see the instructions packaged with the unit or go to [www.jeld-wen.com](http://www.jeld-wen.com).

**DISCLAIMER:**

This drawing and its contents are confidential and are not to be reproduced or copied in whole or in part or used or disclosed to others except as authorized by JELD-WEN Inc.

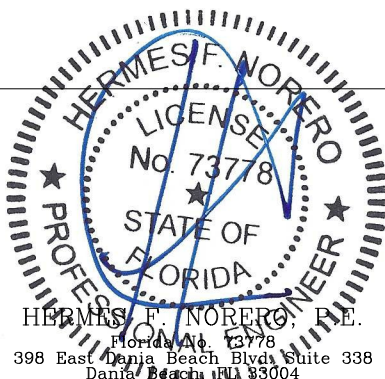

HERMES F. NORERO, P.E.  
Florida No. 73778  
398 East Dania Beach Blvd, Suite 338  
Dania Beach, FL 33004

	DATE: 10/03/2019	3737 LAKEPORT BLVD. <b>JELD WEN</b> KLAMATH FALLS OR, 97601 (800)-535-3936	
DRAWN BY: A. MCMILLAN	SCALE: NTS	Architectural Fiberglass Transom Impact Inswing	
CHECKED BY: D. VEZO	TITLE:		
APPROVED BY: D. VEZO			
RECORD No.:			
REPORT No.:	NCTL-310-19-065	CAD DWG. No.:	REV: A SHEET 1 of 5

MASONRY STRAP  
INSTALLATION

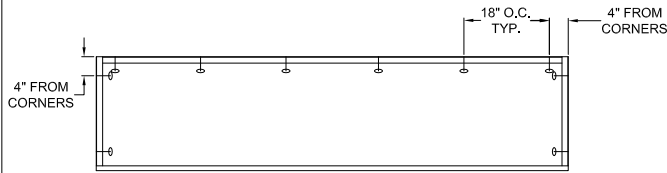

TYPICAL ELEVATION WITH FASTENER SPACING

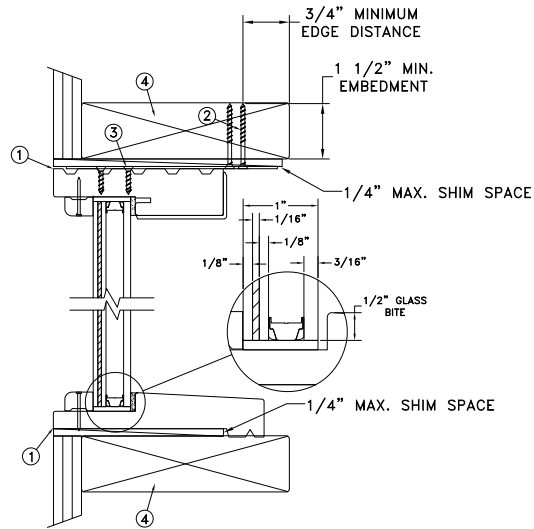

FRAME SECTION (TYP)  
VERTICAL SECTION

MASONRY STRAP NOTES:  
GALVANIZED STEEL 20 GAUGE  
.0396" THICKNESS MIN.  
1.5" WIDTH MIN.

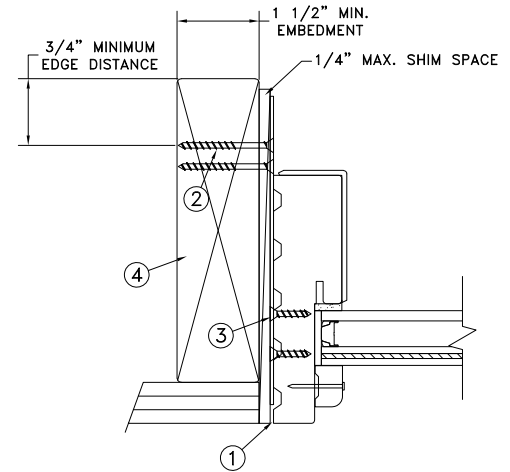

FRAME JAMB SECTION (TYP)  
HORIZONTAL SECTION

MAXIMUM FRAME	DP	IMPACT
99 1/2" x 24"	+65/-70	WZ3

MISSILE LEVEL D

**Installation Notes:**

1. Seal flange/frame to substrate. Sill shall be set on a continuous serpentine bead of structural grade silicone caulk when no fastener is used to anchor the sill (typical).
2. Use 2 - #8 PFH or larger fasteners through masonry strap with sufficient length to penetrate a minimum of 1 1/2" into the buck. For 2x wood frame substrate (min. S.G. = 0.42).
3. Use 2 - #8 PFH or larger fasteners through masonry strap into jamb without penetrating through the jamb into product causing visibility or collateral damage to product.
4. Host structure (wood buck, masonry, steel) to be designed and anchored to properly transfer all loads to the structure. The host structure is the responsibility of the architect or engineer of record for the project of installation.

**General Notes:**

1. The product shown herein is designed, tested and manufactured to comply with the wind load criteria of the adopted International Building Code (IBC), the International Residential Code (IRC), the Florida Building Code (FBC) and the industry requirement for the stated conditions.
2. All glazing shall conform to ASTM E1300.
3. At minimum, glazing is 3.0mm tempered - 12.0mm airspace - 3.0mm annealed - 2.3mm PVB interlayer by kurraray - 3.0mm annealed insulated glass.
4. Use structural or composite shims where required.

This schedule addresses only the fasteners required to anchor the unit to achieve the rated design pressure and impact performance (where applicable) up to the size limitations noted. It is not intended as a guide to the installation process and does not address the sealing consideration that may arise in different wall conditions. For the complete installation procedure, see the instructions packaged with the unit or go to [www.jeld-wen.com](http://www.jeld-wen.com).

**DISCLAIMER:**

This drawing and its contents are confidential and are not to be reproduced or copied in whole or in part or used or disclosed to others except as authorized by JELD-WEN Inc.

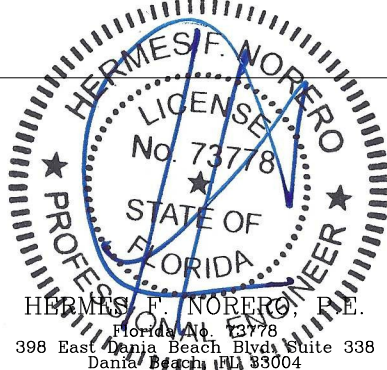

DATE: 10/03/2019	3737 LAKEPORT BLVD. <b>JELD WEN</b> KLAMATH FALLS OR, 97601 (800)-535-3936
DRAWN BY: A. MCMILLAN	SCALE: NTS
CHECKED BY: D. VEZO	TITLE: Architectural Fiberglass Transom Impact Inswing
APPROVED BY: D. VEZO	
RECORD No.: D015646	
REPORT No.: NCTL-310-19-065	CAD DWG. No.: —
	REV: A SHEET 2 of 5

CONCRETE/MASONRY  
INSTALLATION

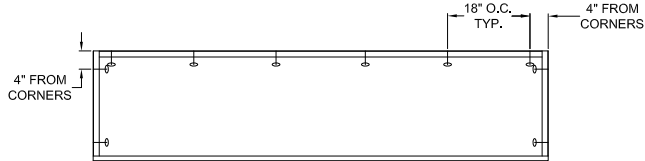

TYPICAL ELEVATION WITH FASTENER SPACING

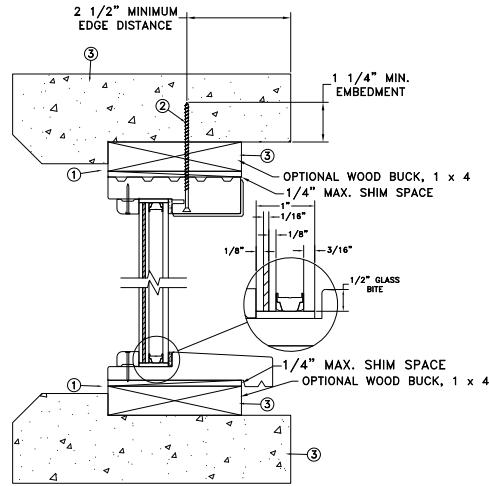

FRAME SECTION (TYP)  
VERTICAL SECTION

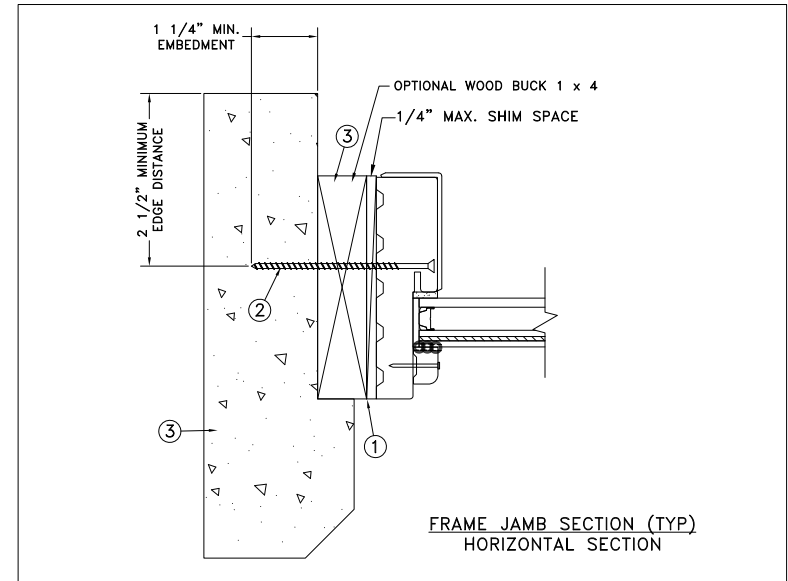

FRAME JAMB SECTION (TYP)  
HORIZONTAL SECTION

MAXIMUM FRAME	DP	IMPACT
99 1/2" x 24"	+65/-70	WZ3

MISSILE LEVEL D

**Installation Notes:**

1. Seal flange/frame to substrate. Sill shall be set on a continuous serpentine bead of structural grade silicone caulk when no fastener is used to anchor the sill (typical).
2. Use 1/4" Tapcon or equivalent fasteners through frame with sufficient length to penetrate a minimum of 1 1/4" into concrete or masonry at each location with a 2 1/2" min. from edge distance. For concrete (min. fc = 3000 psi) or masonry substrate (CMU shall adhere to ASTM C90).
3. Host structure (wood buck, masonry, steel) to be designed and anchored to properly transfer all loads to the structure. The host structure is the responsibility of the architect or engineer of record for the project of installation.

**General Notes:**

1. The product shown herein is designed, tested and manufactured to comply with the wind load criteria of the adopted International Building Code (IBC), the International Residential Code (IRC), the Florida Building Code (FBC) and the industry requirement for the stated conditions.
2. All glazing shall conform to ASTM E1300.
3. At minimum, glazing is 3.0mm tempered - 12.0mm airspace - 3.0mm annealed - 2.3mm PVB interlayer by kurraray - 3.0mm annealed insulated glass.
4. Use structural or composite shims where required.

This schedule addresses only the fasteners required to anchor the unit to achieve the rated design pressure and impact performance (where applicable) up to the size limitations noted. It is not intended as a guide to the installation process and does not address the sealing consideration that may arise in different wall conditions. For the complete installation procedure, see the instructions packaged with the unit or go to [www.jeld-wen.com](http://www.jeld-wen.com).

**DISCLAIMER:**

This drawing and its contents are confidential and are not to be reproduced or copied in whole or in part or used or disclosed to others except as authorized by JELD-WEN Inc.

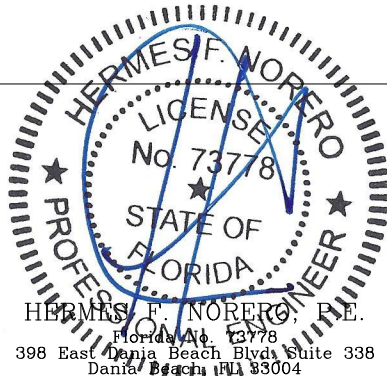

HERMES F. NORERO, P.E.  
Florida No. 73778  
398 East Dania Beach Blvd, Suite 338  
Dania Beach, FL 33004

	DATE: 10/03/2019	<b>JELD WEN</b> 3737 LAKEPORT BLVD. KLAMATH FALLS OR, 97601 (800)-535-3936
DRAWN BY: A. MCMILLAN	SCALE: NTS	
CHECKED BY: D. VEZO	TITLE: Architectural Fiberglass Transom Impact Inswing	
APPROVED BY: D. VEZO		
RECORD No.: D015646		
REPORT No.: NCTL-310-19-065	CAD DWG. No.: —	REV: A SHEET 3 of 5

CONCRETE/MASONRY  
INSTALLATION

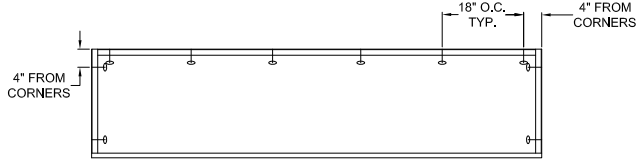

TYPICAL ELEVATION WITH FASTENER SPACING

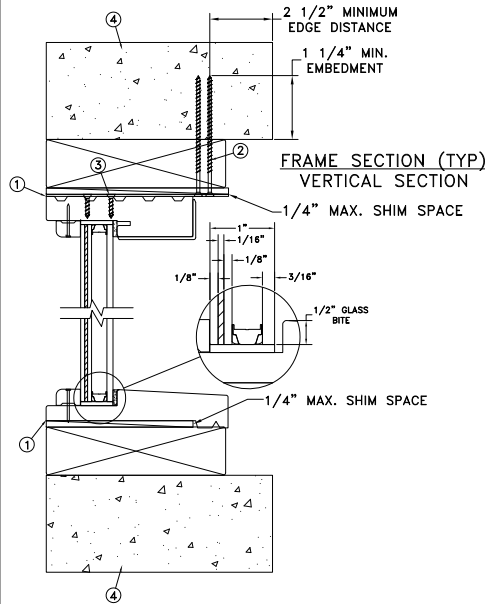

MASONRY STRAP NOTES:  
GALVANIZED STEEL 20 GAUGE  
.0396" THICKNESS MIN.  
1.5" WIDTH MIN.

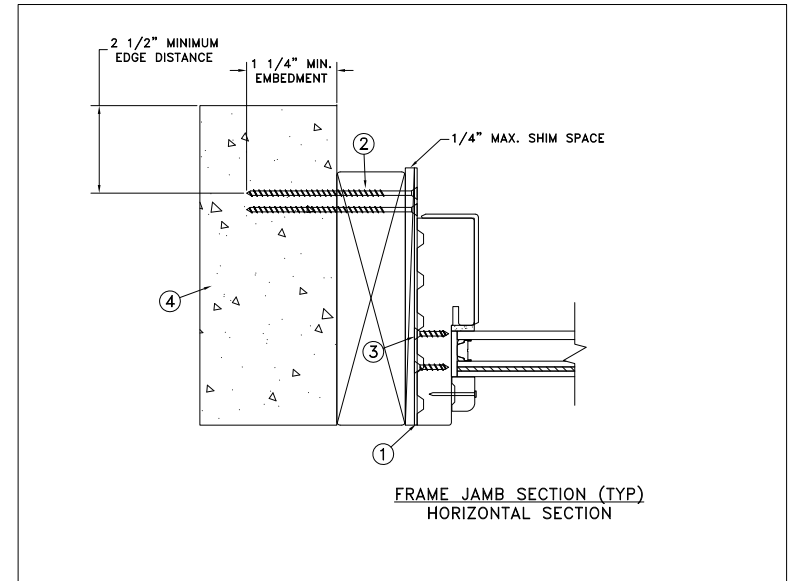

FRAME JAMB SECTION (TYP)  
HORIZONTAL SECTION

MAXIMUM FRAME	DP	IMPACT
99 1/2" x 24"	+65/-70	WZ3

MISSILE LEVEL D

**Installation Notes:**

1. Seal flange/frame to substrate. Sill shall be set on a continuous serpentine bead of structural grade silicone caulk when no fastener is used to anchor the sill (typical).
2. Use (2) - 1/4" Tapcon or equivalent fasteners through strap with sufficient length to penetrate a minimum of 1 1/4" into concrete or masonry at each location with a 2 1/2" min. from edge distance. For concrete (min. fc = 3000 psi) or masonry substrate (CMU shall adhere to ASTM C90).
3. Use 2 - #8 PFH or larger fasteners through masonry strap into jamb without penetrating through the jamb into product causing visibility or collateral damage to product.
4. Host structure (wood buck, masonry, steel) to be designed and anchored to properly transfer all loads to the structure. The host structure is the responsibility of the architect or engineer of record for the project of installation.

**General Notes:**

1. The product shown herein is designed, tested and manufactured to comply with the wind load criteria of the adopted International Building Code (IBC), the International Residential Code (IRC), the Florida Building Code (FBC) and the industry requirement for the stated conditions.
2. All glazing shall conform to ASTM E1300.
3. At minimum, glazing is 3.0mm tempered - 12.0mm airspace - 3.0mm annealed - 2.3mm PVB interlayer by kurraray - 3.0mm annealed insulated glass.
4. Use structural or composite shims where required.

This schedule addresses only the fasteners required to anchor the unit to achieve the rated design pressure and impact performance (where applicable) up to the size limitations noted. It is not intended as a guide to the installation process and does not address the sealing consideration that may arise in different wall conditions. For the complete installation procedure, see the instructions packaged with the unit or go to [www.jeld-wen.com](http://www.jeld-wen.com).

**DISCLAIMER:**

This drawing and its contents are confidential and are not to be reproduced or copied in whole or in part or used or disclosed to others except as authorized by JELD-WEN Inc.

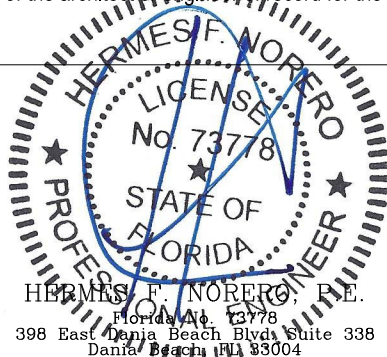

	DATE: 10/03/2019	<b>JELD-WEN</b> 3737 LAKEPORT BLVD. KLAMATH FALLS OR, 97601 (800)-535-3936	
DRAWN BY: A. MCMILLAN	SCALE: NTS		
CHECKED BY: D. VEZO	TITLE: Architectural Fiberglass Transom Impact Inswing		
APPROVED BY: D. VEZO			
RECORD No.: D015646			
REPORT No.: NCTL-310-19-065	CAD DWG. No.: —	REV: A	SHEET 4 of 5

MASONRY STRAP  
INSTALLATION

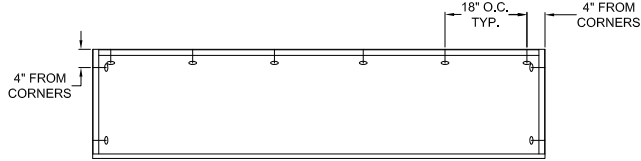

TYPICAL ELEVATION WITH FASTENER SPACING

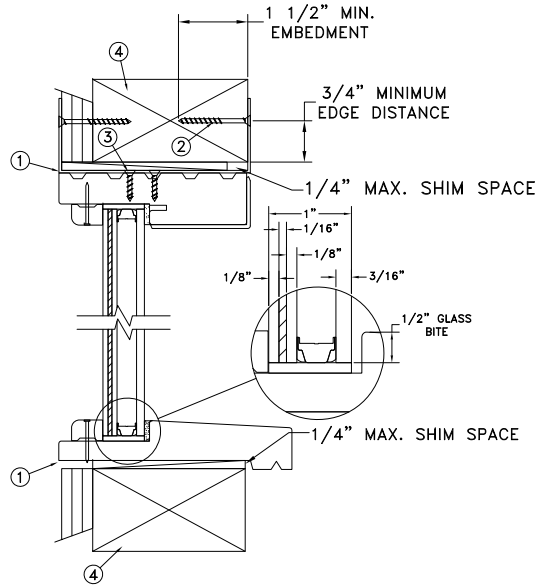

FRAME SECTION (TYP)  
VERTICAL SECTION

MASONRY STRAP NOTES:  
GALVANIZED STEEL 20 GAUGE  
.0396" THICKNESS MIN.  
1.5" WIDTH MIN.

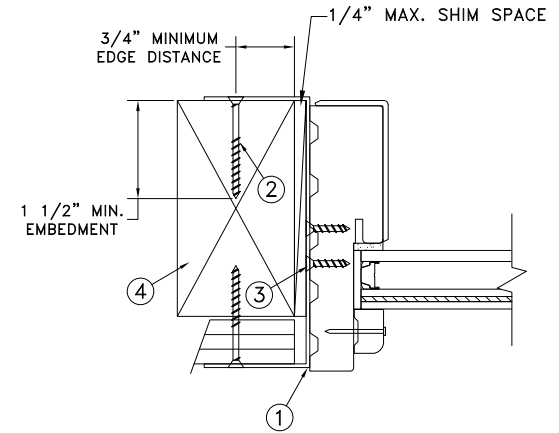

FRAME JAMB SECTION (TYP)  
HORIZONTAL SECTION

MAXIMUM FRAME	DP	IMPACT
99 1/2" x 24"	+65/-70	WZ3

MISSILE LEVEL D

**Installation Notes:**

1. Seal flange/frame to substrate. Sill shall be set on a continuous serpentine bead of structural grade silicone caulk when no fastener is used to anchor the sill (typical).
2. Use min. 2 - #8 PFH or larger fasteners through masonry strap with sufficient length to penetrate a minimum of 1 1/2" into the buck. Bend straps around both sides of the buck. For 2x wood frame substrate (min. S.G. = 0.42).
3. Use min. 2 - #8 PFH or larger fasteners through masonry strap into jamb without penetrating through the jamb into product causing visibility or collateral damage to product.
4. Host structure (wood buck, masonry, steel) to be designed and anchored to properly transfer all loads to the structure. The host structure is the responsibility of the architect or engineer of record for the project of installation.

**General Notes:**

1. The product shown herein is designed, tested and manufactured to comply with the wind load criteria of the adopted International Building Code (IBC), the International Residential Code (IRC), the Florida Building Code (FBC) and the industry requirement for the stated conditions.
2. All glazing shall conform to ASTM E1300.
3. At minimum, glazing is 3.0mm tempered - 12.0mm airspace - 3.0mm annealed - 2.3mm PVB interlayer by kurraray - 3.0mm annealed insulated glass.
4. Use structural or composite shims where required.

This schedule addresses only the fasteners required to anchor the unit to achieve the rated design pressure and impact performance (where applicable) up to the size limitations noted. It is not intended as a guide to the installation process and does not address the sealing consideration that may arise in different wall conditions. For the complete installation procedure, see the instructions packaged with the unit or go to [www.jeld-wen.com](http://www.jeld-wen.com).

**DISCLAIMER:**

This drawing and its contents are confidential and are not to be reproduced or copied in whole or in part or used or disclosed to others except as authorized by JELD-WEN Inc.

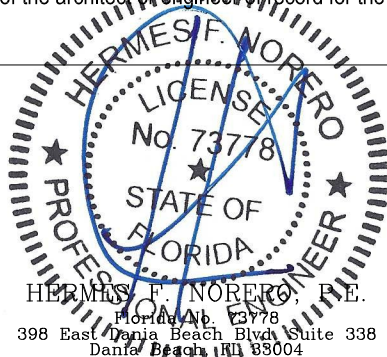

DATE: 10/03/2019	3737 LAKEPORT BLVD. <b>JELD WEN</b> KLAMATH FALLS OR, 97601 (800)-535-3936	
DRAWN BY: A. MCMILLAN	SCALE: NTS	
CHECKED BY: D. VEZO	TITLE: Architectural Fiberglass Transom Impact Inswing	
APPROVED BY: D. VEZO		
RECORD No.:		
REPORT No.:	CAD DWG. No.:	
NCTL-310-19-065	REV: A	SHEET 5 of 5